

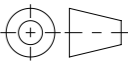

Werkstoff: 1.4301 (X5CrNi18-10)		Gewicht: 0.20 kg		 www.aco.ch	ACO AG Industrie Kleinzaun CH-8754 Netstal Tel. 055 / 645 53 00 E-Mail: aco@aco.ch			
zul. Abweichung: Norm		Oberfläche: DIN ISO 1302			Diese Zeichnung darf weder kopiert noch dritten Personen, insbesondere zum Zweck anderweitiger Benutzung mitgeteilt werden und bleibt unser Eigentum. Copyright reserved! © ACO AG			
Erstellt:	Datum: 03.10.2025	Name: bae	Massstab: 1:1	Masseinheit: Millimeter	Projektion: ISO-E		Index: -	
Freigegeben:	06.10.2025	bae		Blatt / Anz.: 1 / 1				
Status:	Freigegeben							
ACO-Standard Rost 142x142 für DN100 zu Dachablauf Art. Nr.: 2023207				Zeichnung Nr.: CH 2023207		Erstaussgabe		