

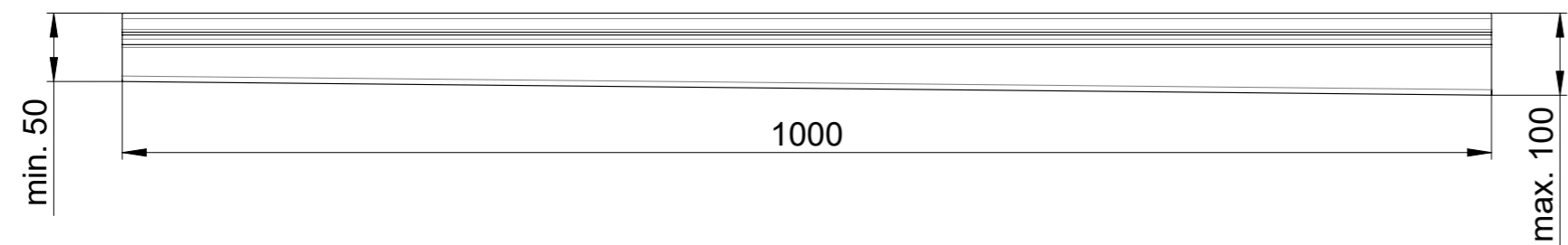

maximal 10mm Gefälle pro Meter

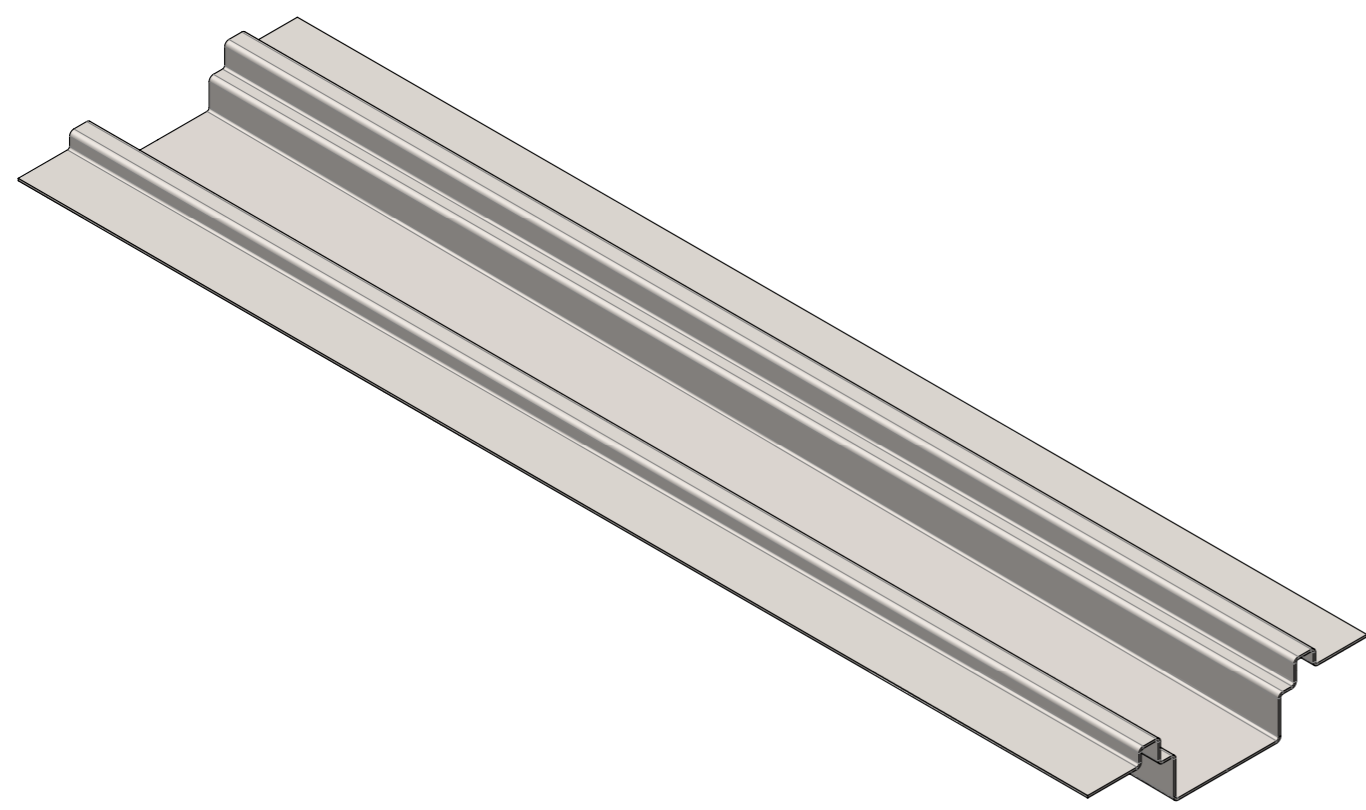

(1:1)

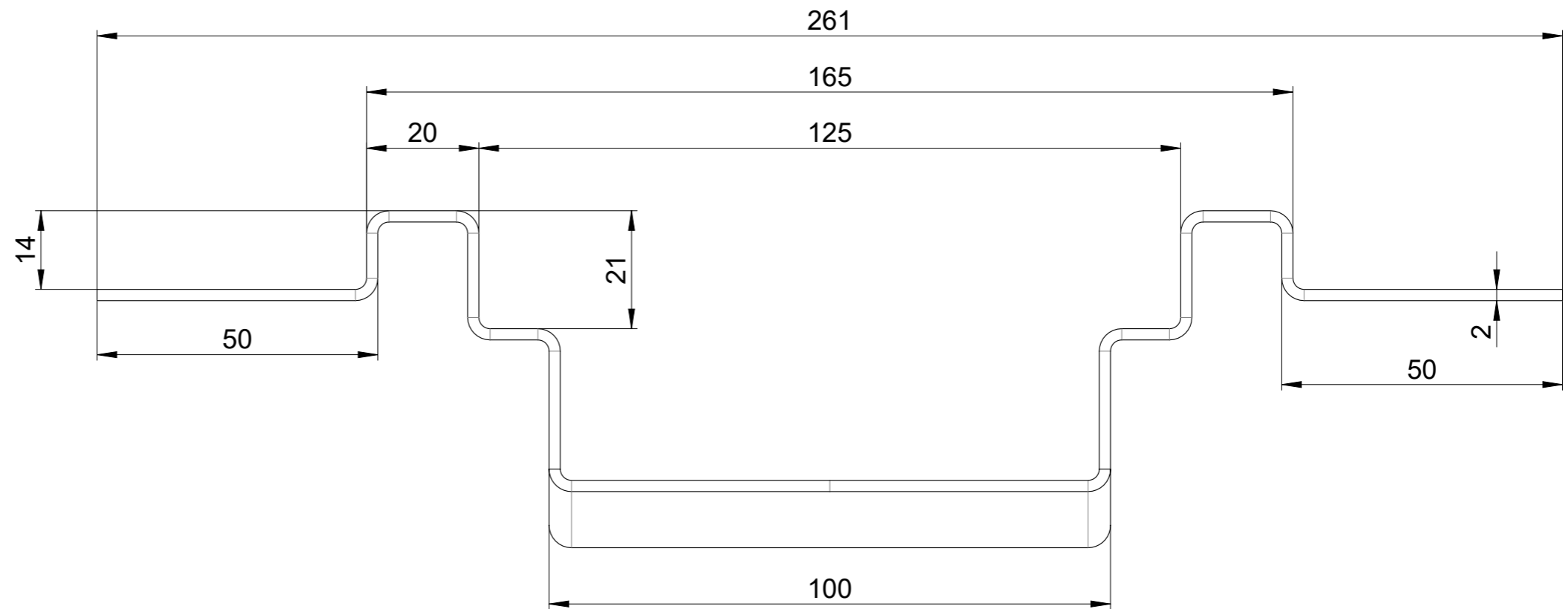

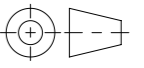
Werkstoff: <b>1.4301 (X5CrNi18-10)</b>		Gewicht: <b>6.00 kg</b>		 <b>ACO AG</b> Industrie Kleinzaun CH-8754 Netstal Tel. 055 / 645 53 00 E-Mail: aco@aco.ch	
zul. Abweichung: <b>Norm</b>		Oberfläche: <b>DIN ISO 1302</b>			
Erstellt:	Datum: 29.10.2021	Name: AB	Massstab:  <h1>1:5</h1>	Masseinheit: <b>Millimeter</b>	Projektion: ISO-E  Diese Zeichnung darf weder kopiert noch dritten Personen, insbesondere zum Zweck anderweitiger Benutzung mitgeteilt werden und bleibt unser Eigentum. Copyright reserved! © ACO AG
Freigegeben:	15.09.2024	Hans		Blatt / Anz.: <b>1 / 1</b>	
Status:	Freigegeben				
Haustechnik <b>Kastenrinne K050-K100</b> mit Sohlengefälle Art. Nr.: 2090517				Zeichnung Nr.: <h1>CH 420254</h1>	
				Index: <h1>B</h1>	
				B 12.09.2024 Hans SAP-Nr. A 04.10.2023 nae Bezeichnung	

Plattendatum: 15.09.2024