

Einlauf (180°): DN200 - Ø200
Rohrmat.: PE-HD

Auslauf (0°): DN200 - Ø200
Rohrmat.: PE-HD

Ölspeichervolumen: 460 Liter

Gesamtgewicht: 1800kg

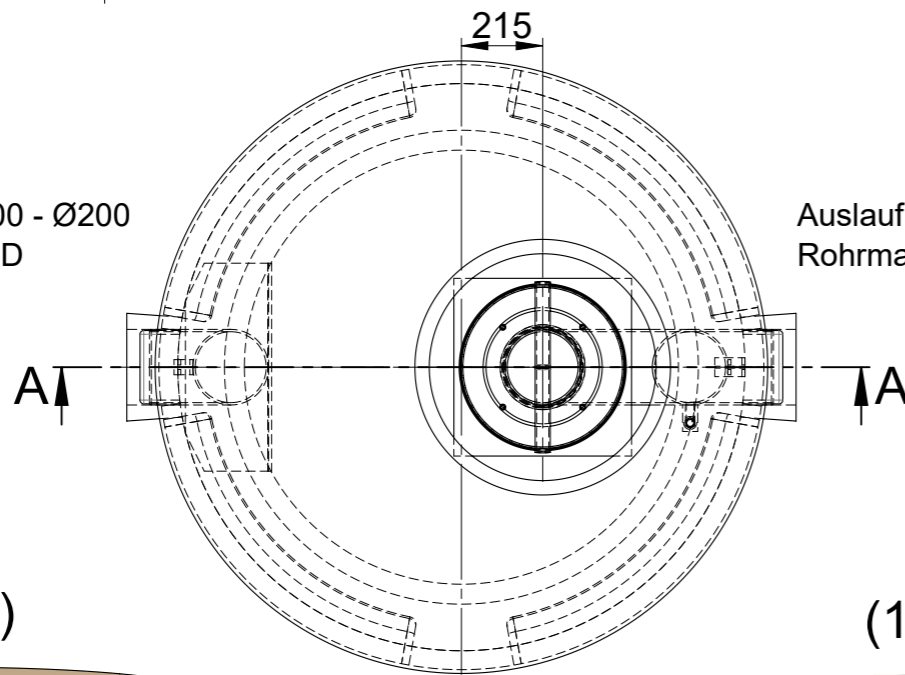

Kontroll exemplar

Datum : _____

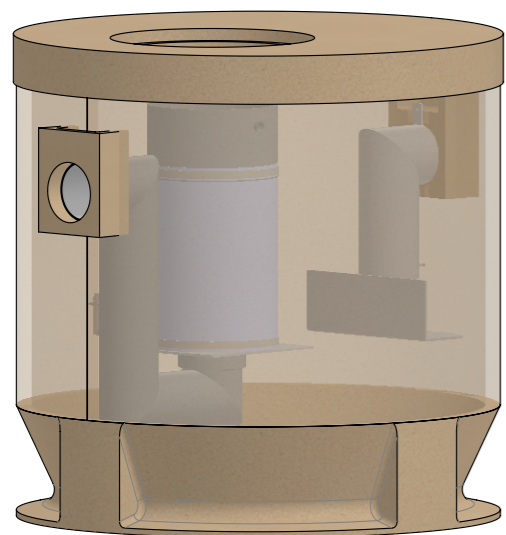

Stempel / Signum : _____

(1:25)

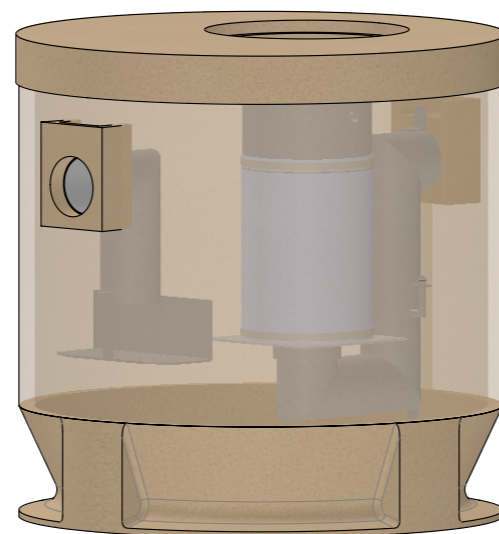

(1:25)

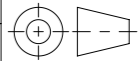

Werkstoff:		Gewicht: 1750.63 kg		 www.aco.ch	ACO AG Industrie Kleinzaun CH-8754 Netstal Tel. 055 / 645 53 00 E-Mail: aco@aco.ch	
zul. Abweichung: Norm		Oberfläche: DIN ISO 1302				
Erstellt:	Datum: 13.04.2018	Name: Gric	Massstab: 1:20	Masseinheit: Millimeter	Projektion: ISO-E	Diese Zeichnung darf weder kopiert noch dritten Personen, insbesondere zum Zweck anderweitiger Benutzung mitgeteilt werden und bleibt unser Eigentum. Copyright reserved! © ACO AG
Freigegeben:	07.09.2024	dca		Blatt / Anz.: 1 / 1		
Status:	Freigegeben					
Bauelemente Polycom Typ 2 Klasse 1 - NG 15 l/s Art. Nr.: 2092009				Zeichnung Nr.: CH 444031		Index: D
D	06.09.2024	dca	SAP Nr.			
C	15.09.2020	KJ	Gewicht Check			