

Einlauf (180°): DN200 - Ø200
Rohrmat.: PE-HD

Auslauf (0°): DN200 - Ø200
Rohrmat.: PE-HD

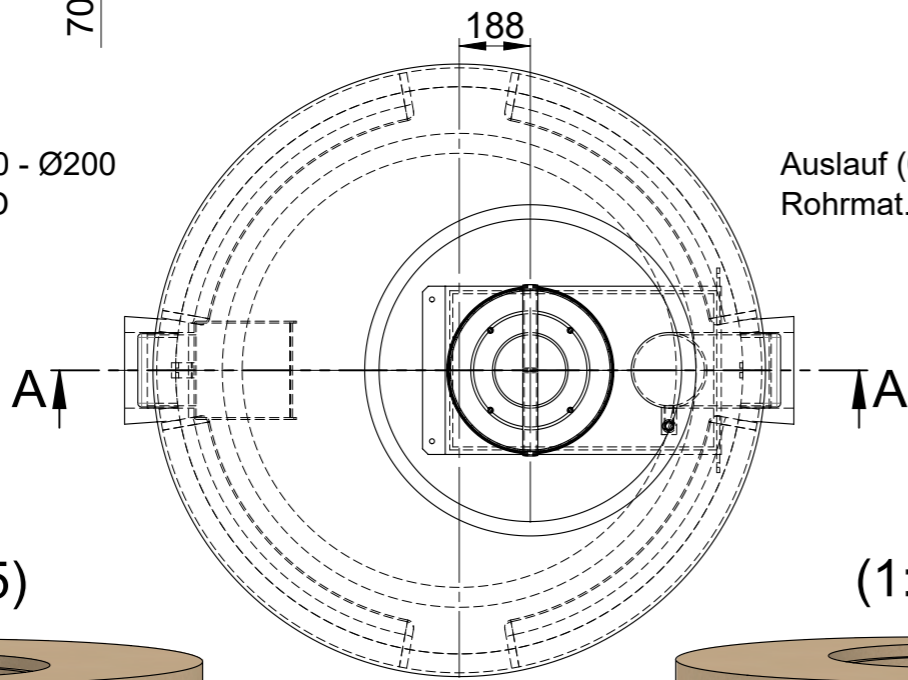

Ölspeichervolumen: 760 Liter

Gesamtgewicht: 1850kg

Kontroll-exemplar

Datum : _____

Stempel / Signum : _____

(1:25)

(1:25)

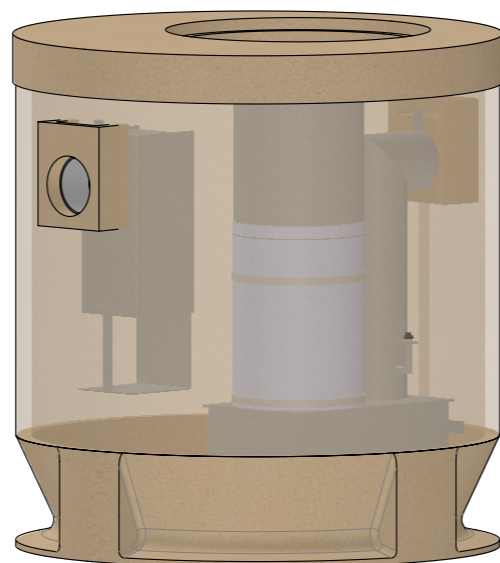
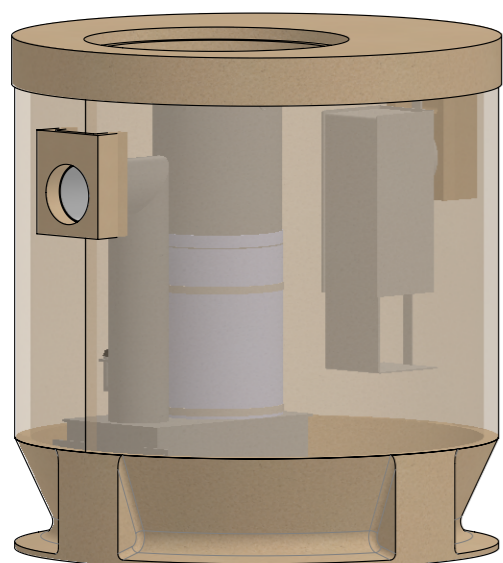

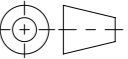
Werkstoff:		Gewicht: 1738.56 kg		 www.aco.ch	ACO AG Industrie Kleinzaun CH-8754 Netstal Tel. 055 / 645 53 00 E-Mail: aco@aco.ch		
zul. Abweichung: Norm		Oberfläche: DIN ISO 1302			Diese Zeichnung darf weder kopiert noch dritten Personen, insbesondere zum Zweck anderweitiger Benutzung mitgeteilt werden und bleibt unser Eigentum. Copyright reserved! © ACO AG		
Erstellt:	Datum: 13.04.2018	Name: Gric	Massstab: 1:20	Masseinheit: Millimeter	Projektion: ISO-E		
Freigegeben:	07.09.2024	dca		Blatt / Anz.: 1 / 1			
Status:	Freigegeben						
Bauelemente Polycom Typ 2 Klasse 1 - NG 20 l/s Art. Nr.: 2092010				Zeichnung Nr.: CH 444032		Index: D	
D 06.09.2024		dca	SAP Nr.				
C 15.09.2020		KJ	Gewicht Check				