

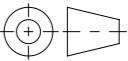

Werkstoff: <b>1.4301</b>		Gewicht: <b>0.56 kg</b>		 <a href="http://www.aco.ch">www.aco.ch</a>	<b>ACO AG</b> Industrie Kleinzaun CH-8754 Netstal Tel. 055 / 645 53 00 E-Mail: <a href="mailto:aco@aco.ch">aco@aco.ch</a>		 Diese Zeichnung darf weder kopiert noch dritten Personen, insbesondere zum Zweck anderweitiger Benutzung mitgeteilt werden und bleibt unser Eigentum. Copyright reserved! © ACO AG
zul. Abweichung: <b>Norm</b>		Oberfläche: <b>DIN ISO 1302</b>			Projektion: ISO-E 		
Erstellt:	Datum: 03.10.2025	Name: bae	Massstab:  <b>1:2</b>	Masseinheit: <b>Millimeter</b>	Blatt / Anz.: <b>1 / 1</b>		
Freigegeben:	06.10.2025	bae					
Status:	Freigegeben						
ACO-Standard <b>Rostaufnahme Siebloch DN100 148x148 V2A</b>				Zeichnung Nr.:		Index:	
Art. Nr.: 3010270				<b>CH 3010270</b>		<b>-</b>	
				Erstausgabe			