

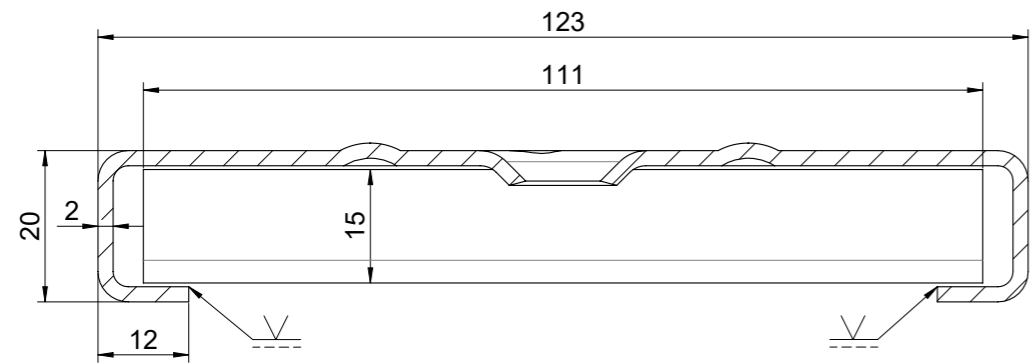

B-B (1:1)

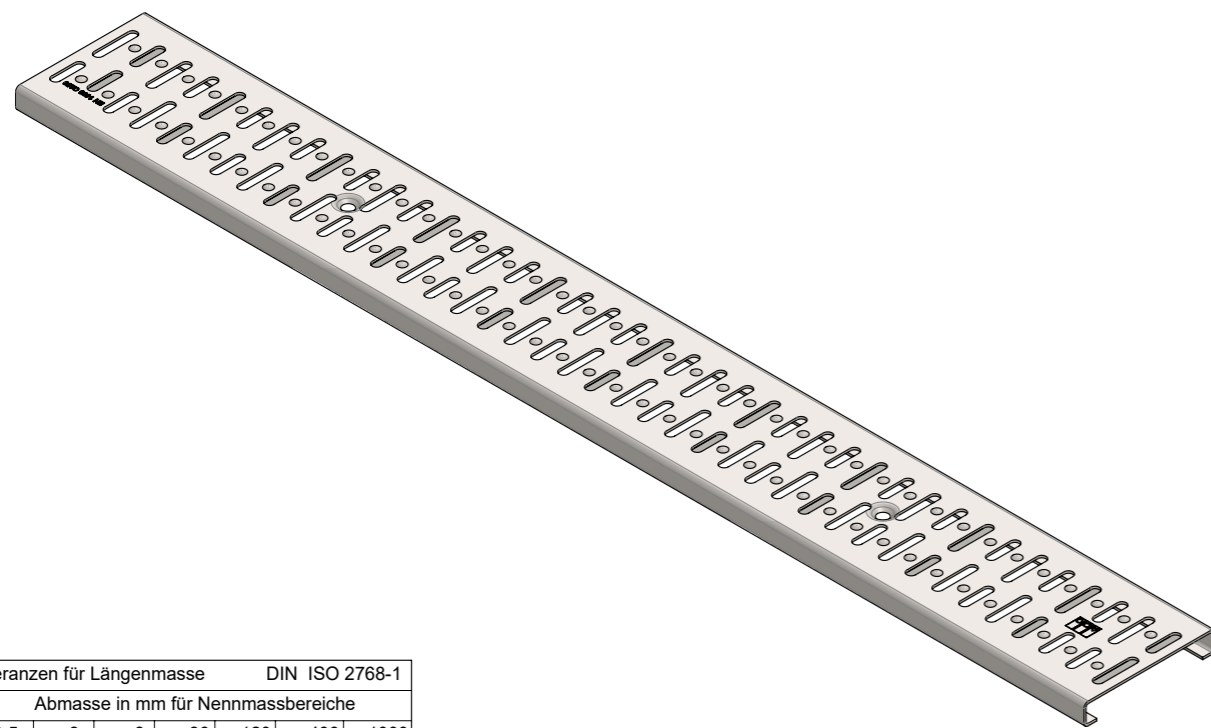

A-A

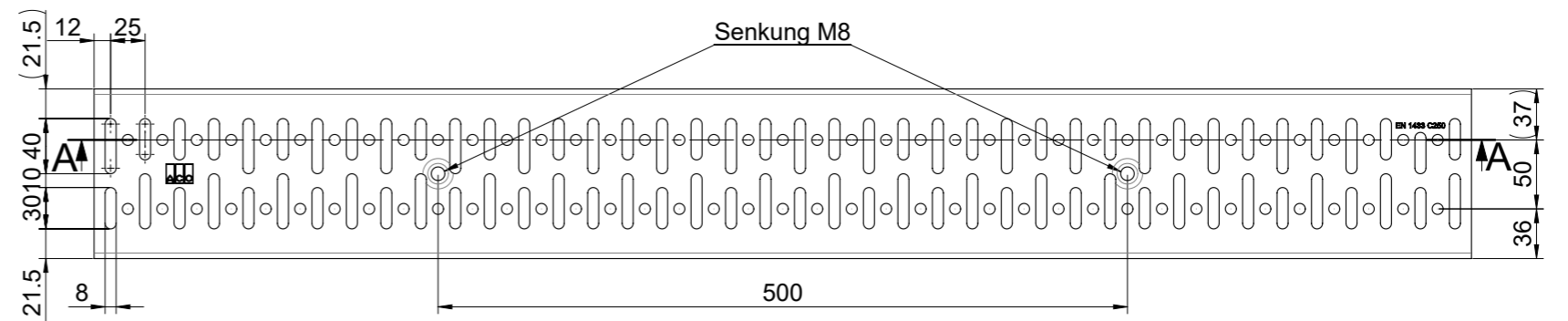
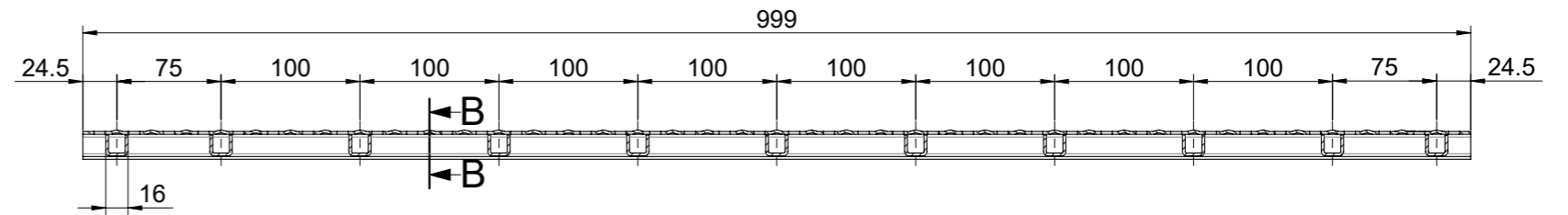

Pos	Menge	Index	Beschreibung	Zn. Nr.	Material	Gewicht
1	1	+	Schlitzrost	420052	1.4301 (X5CrNi18-10)	2.38
2	11		Verstärkung Roste NW100	420051_1	1.4301 (X5CrNi18-10)	0.07

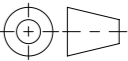
Werkstoff:		Gewicht: 3.16 kg		 ACO AG Industrie Kleinzaun CH-8754 Netstal Tel. 055 / 645 53 00 E-Mail: aco@aco.ch	
zul. Abweichung: Norm		Oberfläche: DIN ISO 1302			
Erstellt:	Datum: 07.09.2022	Name: AB	Massstab: 1:5	Masseinheit: Millimeter	Projektion: ISO-E  Diese Zeichnung darf weder kopiert noch dritten Personen, insbesondere zum Zweck anderweitiger Benutzung mitgeteilt werden und bleibt unser Eigentum. Copyright reserved! © ACO AG
Freigegeben:	07.09.2022	AB		Blatt / Anz.: 1 / 1	
Status:	Freigegeben				
Bauelemente Schlitzrost C250, arretierbar, Schlitzweite 40x8 + 30x8 Art. Nr.: 420052				Zeichnung Nr.: CH 420051 Index: -	
				Erstaussgabe	

Allgemeintoleranzen für Längenmasse DIN ISO 2768-1

Genauigkeitsgrad	Abmasse in mm für Nennmassbereiche						
	> 0,5 ... 3	> 3 ... 6	> 6 ... 30	> 30 ... 120	> 120 ... 400	> 400 ... 1000	> 1000 ... 2000
m (mittel)	± 0.1	± 0.1	± 0.2	± 0.3	± 0.5	± 0.8	± 1.2