

Einlauf (180°): DN200 - Ø200  
Rohrmat.: PE-HD

Auslauf (0°): DN200 - Ø200  
Rohrmat.: PE-HD

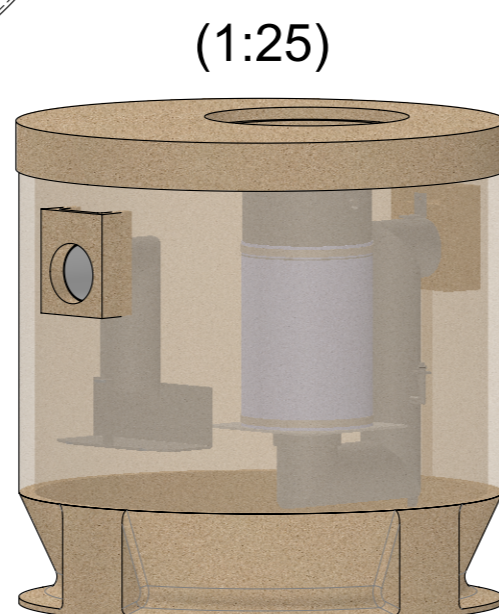
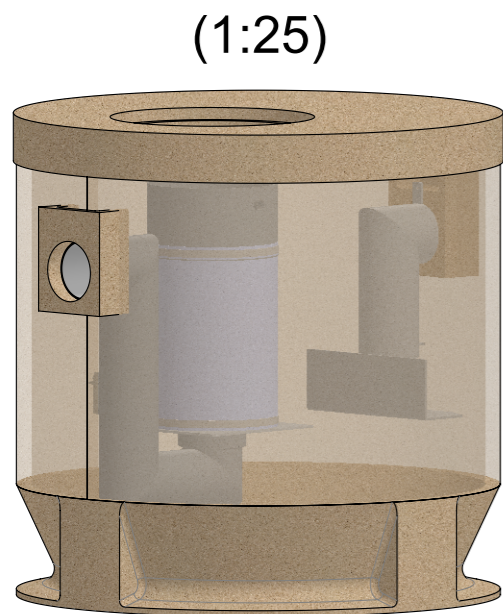
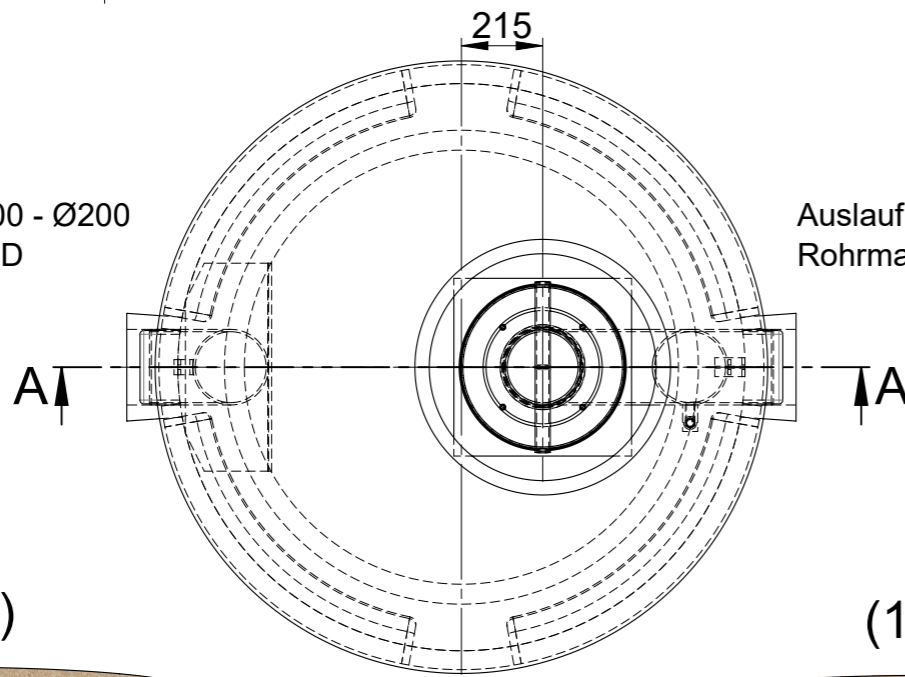

Ölspeichervolumen: 460 Liter Gesamtgewicht: 1800kg

Artikel-Nr.	Bezeichnung	Menge
400036	Einlaufteil DN200 aus PE-HD	1
405880	Auslaufteil DN200 aus PE-HD	1
700750	Koaleszenzelement DN200	1

Werkstoff:	Gewicht: 1750.63 kg	 <b>ACO Passavant AG</b> Industrie Kleinzaun CH-8754 Netstal Tel. 055 / 645 53 00 E-Mail: aco@aco.ch
zul. Abweichung: Norm	Oberfläche: DIN ISO 1302	

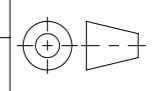
Erstellt:	Datum:	Name:	Massstab: <b>1:20</b>	Masseinheit: Millimeter	Projektion: ISO-E 	Diese Zeichnung darf weder kopiert noch dritten Personen, insbesondere zum Zweck anderweitiger Benutzung mitgeteilt werden und bleibt unser Eigentum. Copyright reserved! © ACO Passavant AG
Freigegeben:	13.04.2018	Gric				
Status:	15.09.2020	KJ	Blatt / Anz.: 1 / 1			

Bauelemente <b>Polycom Typ 2</b> Klasse 1 - NG 15 l/s Art. Nr.: 444031			Zeichnung Nr.: <b>CH 444031</b>		Index: <b>C</b>
C	15.09.2020	KJ	Gewicht Check		
B	14.05.2020	KJ	Deckelstärke anpassen		