

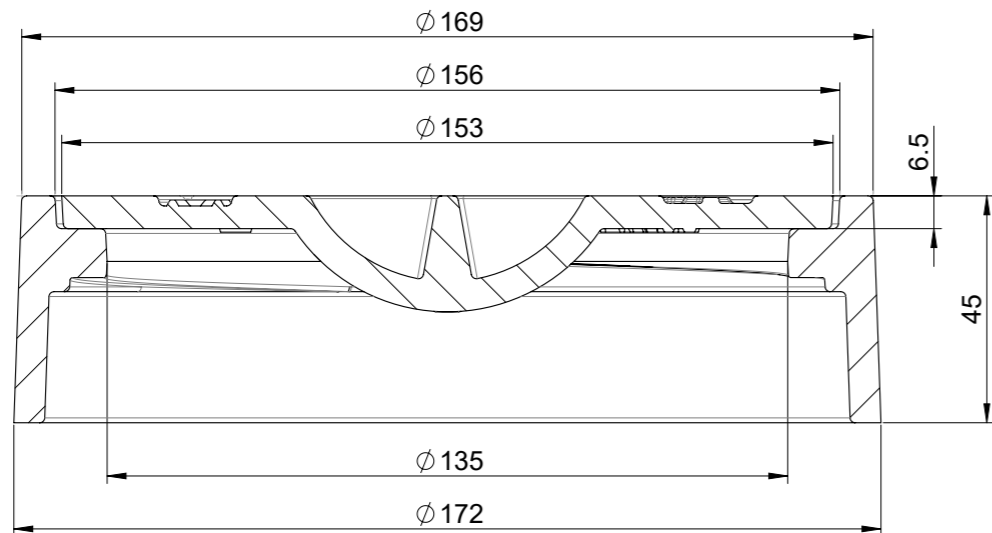

A-A



Pos	Menge	Index	Beschreibung	Zn. Nr.	Material	Gewicht
1	1	+	Rahmen DN150	I1-P01-628-21-12	0.6025 (EN-GJL-250)	1.44
2	1	+	Putzdeckel DN150	I1-P01-628-21-11	0.6025 (EN-GJL-250)	0.94

Werkstoff:		Gewicht: <b>kg</b>		 www.aco.ch	<b>ACO AG</b> Industrie Kleinzaun CH-8754 Netstal Tel. 055 / 645 53 00 E-Mail: aco@aco.ch		
zul. Abweichung: <b>Norm</b>		Oberfläche: <b>DIN ISO 1302</b>					
Erstellt:	Datum: 01.06.2022	Name: AB	<b>1:1.5</b>	Masseinheit: <b>Millimeter</b>	Projektion: ISO-E	Diese Zeichnung darf weder kopiert noch dritten Personen, insbesondere zum Zweck anderweitiger Benutzung mitgeteilt werden und bleibt unser Eigentum. Copyright reserved! © ACO AG	
Freigegeben:	10.09.2024	dca		Blatt / Anz.: 1 / 1			
Status:	Freigegeben						
<b>Bauelemente</b> <b>Putzdeckel für Kunststoffrohre DN150</b> mit Bojonettverschluss Art. Nr.: 2089911				Zeichnung Nr.: <b>CH 77647</b>		Index: <b>A</b>	
				A	26.08.2024	dca	SAP Nr.
				-	Erstausgabe		

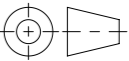
Allgemeintoleranzen für Längenmasse		DIN ISO 2768-1					
Genauigkeitsgrad		Abmasse in mm für Nennmassbereiche					
		0,5	> 3	> 6	> 30	> 120	> 400
		... 3	... 6	... 30	... 120	... 400	... 1000
m (mittel)	(mittel)	± 0.1	± 0.1	± 0.2	± 0.3	± 0.5	± 0.8
							± 1.2

Ploddatum: 11.09.2024